

TECHNISCHE ÄNDERUNGEN VORBEHALTEN · NACHDRUCK UND KOPIEN NUR MIT UNSEREM EINVERSTÄNDNIS · Specifications subject to change without notice · Copyright ELAFLEX

GRUPPE 5 Section	AUSFÜHRUNG WERKSTOFFE · GEWICHT <i>Construction Details Materials · Weight</i>	BÜGEL- FORM <i>Guard Style</i>	SCHLAUCH- ANSCHLUSS <i>Hose Inlet Thread Type + Size</i>	BESTELL- NUMMER <i>Part Number</i>
	Spezifikation	No.	G	Type

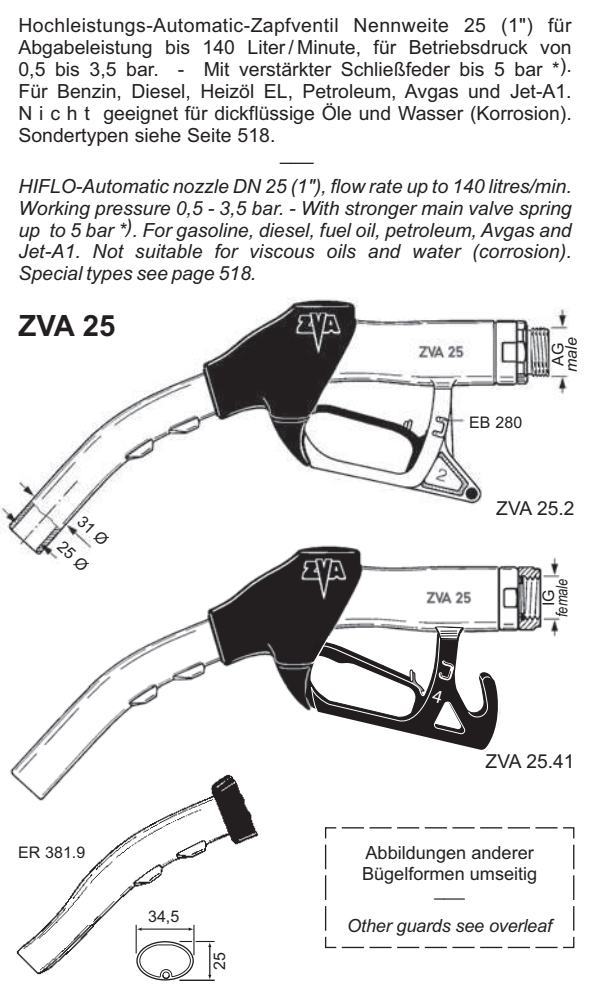

<p>STANDARD-AUSFÜHRUNG:</p> <p>Venturigesteuerte Abschalt-Automatic. Kugel-Kipp-Sicherheitsauslöser. Rückschlagventil für Vollschlauchbetrieb. 3-Stufen-Aufhalteraste mit herausziehbarem Rastenstecker EB 280. Drehbarer Schlauchanschluß DN 25 mit Druckspülung. Grobsieb EK 372 (600 my). Schwarzer Schutzüberzug aus Weich-PVC. Gehäuse, Rohr und Bügel aus Aluminium Innenteile und drehbarer Schlauchanschluss: Edelstahl, Rotguss und Messing. Stahlteile verzinkt und chromatiert. Dichtungen NBR/Polyurethan.</p> <p>Gewicht ≈ 1,5 kg</p> <div style="border: 1px solid black; padding: 5px; margin: 5px 0;"> <p>Entspricht EN 13012 : 2001, ATEX-Kategorie EX II 1G, allen europäischen Eichvorschriften sowie TRbF 513. Deutsche Bauartzulassung PTB Nr. III B/S 1804</p> </div> <p>STANDARD SPECIFICATION:</p> <p>Patented venturi type automatic shut-off with safety cut-out attitude valve. Built-in check valve. 3-speed lever latch with removable latch pin EB 280. Swivel hose inlet DN 25 with pressure flushing. Screen EK 372 (25 mesh). Black plastic cover. Body, spout and guard of aluminum. Internal parts of stainless steel, bronze and acetal resin. Swivel parts of hot stamped brass. Steel parts galvanized and chromated. Seals of NBR/polyurethane.</p> <p>Weight ≈ 1,5 kg</p> <div style="border: 1px solid black; padding: 5px; margin: 5px 0;"> <p>Meets requirements of EN 13012: 2001, ATEX category EX II 1G, all European regulations for weights and measures and TRbF 513. German type approval: PTB No. III B/S 1804</p> </div>	1	R 1" AG 1" BSP male	ZVA 25.1	
	2	R 1" AG 1" BSP male	ZVA 25.2	
	3	R 1" AG 1" BSP male	ZVA 25.3	
		R 1" AG 1" BSP male	mit Blockmagnet ZVA 25.3 M with block magnet	
	4	R 1" AG 1" BSP male	ZVA 25.4	
		R 1" IG 1" BSP female	ZVA 25.41	
		1" NPT IG 1" NPT female	(ZVA 25.45)	
		R 1" IG 1" BSP female	mit Blockmagnet ZVA 25.4 M1 with block magnet	
	6	R 1" IG 1" BSP female	ZVA 25.61	
	6B	R 1" AG 1" BSP male	ZVA 25.6 B	
	8	R 1" AG 1" BSP male	ZVA 25.8	
	8D	R 1" AG 1" BSP male	mit Blockmagnet ZVA 25.8 DM with block magnet	
		R 1" AG 1" BSP male	Block- + Rundmagnet ZVA 25.8 DM rm block + round magnet	
	ZVA 25 m. Spezialrohr ER 381.9 für enge/kritische Einfüllstutzen			ZVA 25...ER
	ZVA 25 + special spout ER 381.9 for narrow/problematic filler necks			



Spezialausführungen / Zusatzausstattungen · Special Types / Accessories	Mit verstärkter Schließfeder EF 362.6 für Betriebsdruck bis 5 bar *) With stronger main valve spring EF 362.6 for W.P. up to 5 bar		ZVA 25...5 bar
	Vereinfachte Ausführung - anstelle des Drehgelenkes mit festem Schlauchanschluss Simplified style with fixed hose inlet "F" instead of swivel hose inlet	R 1" AG 1" BSP male	ZVA 25...F
	Mit Abreißkupplung SSB 25 und Breaktülle BT 21 (schwarz oder farbig) With Safety Swivel Break SSB 25 and break cover BT 21 (black or coloured)	R 1" IG 1" BSP female	ZVA 25...1 F
	Drehgelenk mit Lippendichtung ED 179 FS aus Fluorsilikon bis -50°C Swivel with lip seal ED 179 FS of fluorsilicone, down to -50° C	R 1" AG 1" BSP male	ZVA 25... + SSB 25
		R 1" IG 1" BSP female	ZVA 25... + SSB 25.1
	Stahlteile ersetzt durch rostfreien Stahl, Schalthebel blau rilsanisiert, Membrane aus PTFE, nur mit Festanschluß "F" Steel parts replaced by stainless steel. Lever: blue rilsan coated. Diaphragm: PTFE. With fixed hose inlet "F" only	Dichtungen Polyurethan Seals of polyurethane	ZVA 25...FS
		Dichtungen aus Viton Seals of Viton FKM	ZVA 25...VD
	Auslaufrohr mit Jet A1 Formstück Spout with Jet A1 modification		ZVA 25...Vi
	Gummikappengarnitur: NBR/Messing. Für Rohr ZVA 25 (31Ø) Dust cap assembly: NBR/brass. For spout ZVA 25 (31 mm OD)		ER 381 JET
	Erdungskabelgarnitur: Ms mit plastikummanteltem Kabel. 1200 mm lg Ground cable assembly with brass clamp, wire plastic coated. 1200 mm lg		GKG 25 *)
	Aufschraubbares Schauglas SG 1" aus Rotguss/Naturglas mit eingesetzten Feinsieb 160 my (ES 239.1) aus Edelstahl Thread-on sight glass SG 1" of bronze/natural glass with inserted screen 100 mesh (ES 239.1) of stainless steel		EKG 1200 *)
			SG 1" + ES 239.1

